



CENTRA[®]

Packaged central
laboratory water systems

CENTRA

An award winning range of packaged centralized systems for supplying pure water to one or more laboratories in a building

The new CENTRA range has been designed to transform the installation, control and supply of pure water to a distribution loop. Instead of a traditionally engineered central lab system, comprising of an untidy grouping of reservoir, RO, UV, tubing and pump, you can now have just one integrated system box. The CENTRA also improves the management of your loop system, incorporating an array of system operations, monitors and alarms on its conveniently positioned control panel.



CHOOSE A MODEL TO SUIT YOUR NEEDS

There are five standard and four high flow models, in two CENTRA families – Centralized Distribution Systems and Centralized Purification and Distribution Systems. Every CENTRA system can be customized to your water purity requirements, distribution loop design, feedwater and laboratory applications – feeding everything from glassware washers and autoclaves to high purity polishers such as the PURELAB Ultra.

CENTRALIZED DISTRIBUTION SYSTEMS

- The **CENTRA-MDS** and **LDS** are designed to enhance existing water purification systems such as the PURELAB Prima; storing, controlling and distributing pre-purified water throughout a building via a loop system. The models are differentiated by the size of their reservoirs, 200 liter capacity on the MDS and 350 liters on the LDS. The **CENTRA-RDS** also works with existing water purification systems to store, control and distribute pre-purified water, but in addition features UV photo-oxidation, external deionization cylinder and 0.2µm filter for enhanced bacterial control



CENTRALIZED PURIFICATION AND DISTRIBUTION SYSTEMS

- The **CENTRA-S 200** and **CENTRA-R 200** are complete water purification, storage, control and distribution systems featuring a 200 liter per hour reverse osmosis module and 0.2µm filter. The CENTRA-R 200 additionally features UV photo-oxidation, and a feed to and from a deionization cylinder



The CENTRA range at a glance

Standard CENTRA Model	CENTRALIZED DISTRIBUTION SYSTEMS			CENTRALIZED PURIFICATION AND DISTRIBUTION SYSTEMS	
	MDS	LDS	RDS	S 200	R 200
Typical Flowrate	Up to 18 liters per minute				
High Flow CENTRA Model	N/a	LDS-HFV	RDS-HFV	S 200-HFV	R 200-HFV
Typical Flowrate	N/a	Variable speeds, up to a maximum of 30 liters per minute ¹			
Reservoir Capacity	200 liters	350 liters		350 liters	
Recirculation Pump	✓	✓	✓	✓	✓
Reverse Osmosis				✓	✓
UV Photo-oxidation			✓		✓
0.2µm Filter			✓	✓	✓
Optional Deionization			✓		✓
Optional Composite Vent Filter	✓	✓	✓	✓	✓
System Monitoring/Safety Features	✓	✓	✓	✓	✓
Semi-automated Sanitization of Loop			✓	✓	✓
Requires Pre-treated Water Supply	✓	✓	✓		

¹ Subject to the distribution loop design.

HIGH FLOW VARIABLE SPEED

All standard CENTRA systems deliver a loop flowrate of up to 18 liters per minute. Additionally the CENTRA LDS, RDS, S 200 and R 200 are available as high flow variable speed models (HFV) capable of delivering up to 30 liters per minute. These variable speed systems automatically adapt to user demand. When usage levels are low the water is recirculated around the distribution loop at low flow rates, conserving energy. As demand increases the CENTRA boosts the water flow rate up to a maximum of 30 liters per minute to meet peak demand.

EASY OPERATION AND CONTROL

Operation and monitoring of the system and loop is via a conveniently angled four-button “softkey” control panel at the front of the CENTRA. The adjustable control panel features a large high contrast LCD display, enabling performance parameters, operational mode and process flow to be checked at a glance.

- For remote monitoring of the loop, up to 8 additional remote display/control panels can be connected to the system. In addition the CENTRA can be easily connected to new or existing building management systems



CENTRA-MDS

MINI-DISTRIBUTION SYSTEM

- Integral **200 liter** reservoir
- Loop flowrate of up to 18 liters per minute
- Bacterial filter
- Recirculation pump for distribution of the pre-purified water around the loop system and back into the reservoir
- Access to a range of system monitoring and safety features via the central 'softkey' control panel

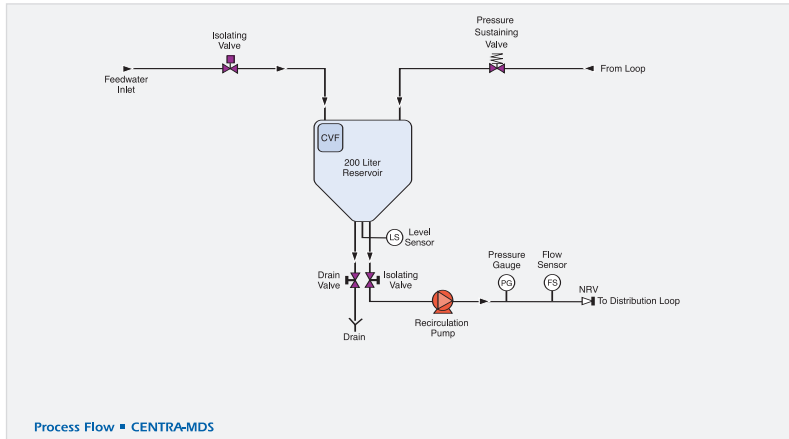

CENTRA-LDS

LARGE DISTRIBUTION SYSTEM

The CENTRA-LDS includes all the features of the CENTRA-MDS but has a larger integral **350 liter** reservoir and is available as a high flow variable speed model (HFV) capable of delivering up to 30 liters per minute.

CENTRA-RDS

RECIRCULATING DISTRIBUTION SYSTEM

The CENTRA-RDS includes all the benefits of the CENTRA-MDS but like the LDS has a larger integral 350 liter reservoir and is available as a high flow variable speed model (HFV). It also includes the following additional features:

- UV photo-oxidation for enhanced bacterial control
- 0.2µm filter to maintain water quality in the distribution loop
- Optional deionization cylinder may be positioned outside the CENTRA-RDS but within the loop.
- Composite vent filter helps keep water quality high by preventing airborne gases and bacteria entering the reservoir
- Additional safety monitoring, including product water quality and consumable change reminder

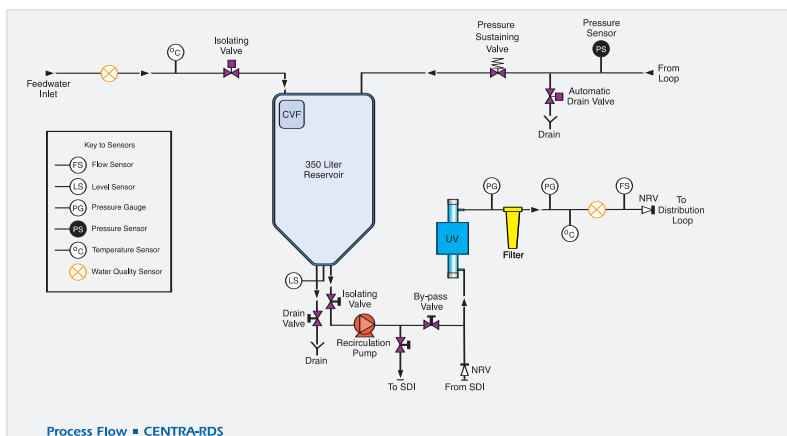

CENTRA-S 200

- Integral **350 liter** reservoir
- Loop flowrate of up to 18 liters per minute with the standard system or a maximum of 30 liters per minute with the high flow variable speed model (HFV)
- 200 liter per hour Reverse Osmosis Membrane and inlet boost pump with pre-filter for pump protection
- 0.2µm filter to maintain water quality in the distribution loop
- Recirculation pump for distribution of the pre-purified water around the loop system and back into the reservoir
- Composite vent filter helps keep water quality high by preventing airborne gases and bacteria entering the reservoir
- Access to a wide range of system monitoring and safety features via the central 'softkey' control panel
- Additional safety monitoring, including product water quality and consumable change reminder

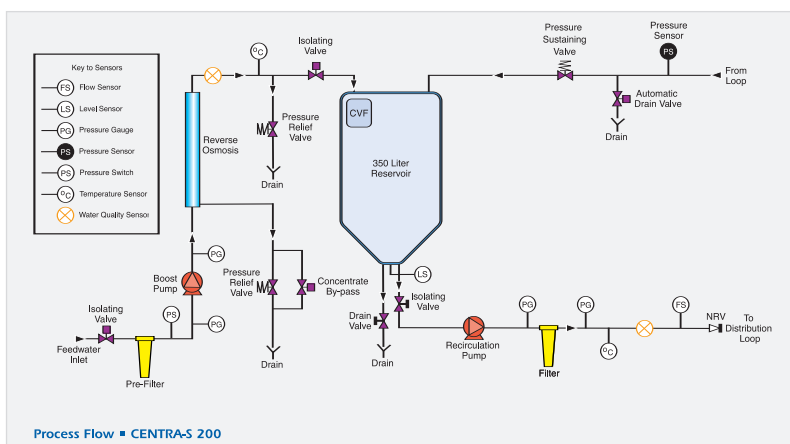

CENTRA-R 200

The CENTRA-R includes all the features of the CENTRA-S plus:

- UV photo-oxidation for enhanced bacterial control
- Optional deionization cylinder may be positioned outside the CENTRA-R but within the loop

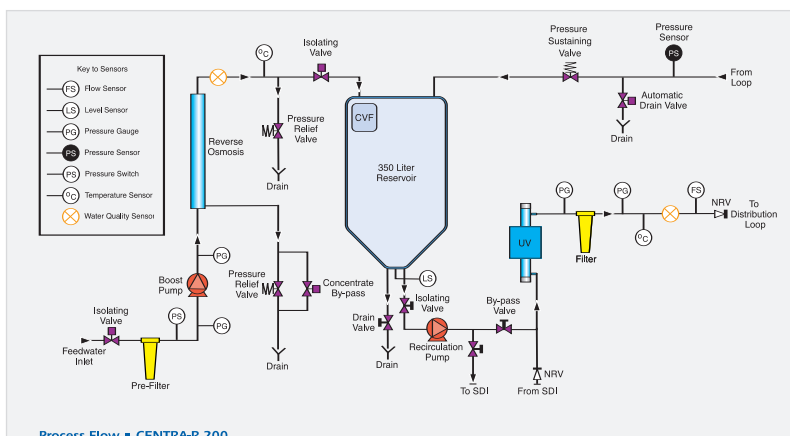

COMPLETE SECURITY

The CENTRA incorporates a wide range of safety features and alarms to ensure pure water quality is not compromised.

- Unique Passkey access to the control panel protects important functions and prevents accidental changes to settings & calibrations. Different tiers of security are provided for flexibility of operation
- For complete peace of mind an internal leak detection system is built into the unit
- Audio visual alarms are initiated in the event of a drop in water quality or reservoir levels
- Validation support documentation can be provided to ensure compliance with standards
- Can be linked to new or existing building management systems



MODERN PRACTICAL DESIGN

The CENTRA would normally be located in a separate plant area or wash room, but its small footprint and modern colour co-ordinated look mean it can also be sited in a laboratory, if this is more convenient. The textured surface is corrosion and chemical resistant, so your CENTRA will continue to look good for many years to come.



COMPREHENSIVE SUPPORT SERVICE

Because the reservoir, components and pipe work are all pre-configured and tested before delivery, you reduce commissioning time. Following installation we offer a full ongoing service and support package to ensure total satisfaction throughout the life of the system.

EASY MAINTENANCE

Maintenance on the CENTRA is very simple and straightforward. Direct access from the front-entry service door, plus quick-fit connections, facilitates easy replacement of consumables. For extra convenience and enhanced quality control the CENTRA-RDS, S 200 and R 200 also features a consumable change reminder.

EASY SANITIZATION

The smooth internal surfaces of the CENTRA combined with the through-flow of water ensure there are no crevices or static areas to harbor bacteria. The CENTRA-MDS and LDS have a simple manual sanitization procedure, while the CENTRA-RDS, R 200 and S 200 additionally feature:

- A manually initiated automatic disinfection routine which simplifies sanitization and maintains control over bacterial and endotoxin levels
- A sprayball* at the entry to the storage reservoir, ensuring all wetted parts are sanitized

GOOD LABORATORY PRACTICE

The CENTRA features RS232 and RS485 interfaces to enable you to make a permanent printed record of performance and system parameters. This allows for compliance with Good Laboratory Practice (GLP) guidelines.

*Not included on CENTRA-MDS



TECHNICAL SPECIFICATIONS

The CENTRA range is designed to deliver the water purity required in your loop. The performance specifications below are intended only as a guide. Each system can be individually specified to meet your particular requirements.

CENTRA Model	MDS	LDS	RDS	S 200	R 200
Product Water Specifications					
Inorganics	As per feed		From feed quality up to 18.2 MΩ·cm ²	RO permeate	Up to 18.2 MΩ·cm ²
TOC	As per feed		From feed quality to <10 ppb ²	Typically <100 ppb ³	<10 ppb ²
Bacteria¹	As per feed		<5 CFU/ml ¹	<50 CFU/ml ¹	<5 CFU/ml ¹
Particles	As per feed		0.2µm filter	0.2µm filter	0.2µm filter
Product Specifications					
Dimensions	Height: 1195mm (47ins) Width: 730mm (28.75ins) Depth: 890mm (35ins)	Height: 1820mm (71.7ins) Width: 730mm (28.75ins) Depth: 890mm (35ins)			
Empty Weight	120kg (264lb)	180kg (396lb)	180kg (396lb)	230kg (507lb)	230kg (507lb)
Working Weight	160kg (352lb)	510kg (1124lb)	510kg (1124lb)	580kg (1279lb)	580kg (1279lb)
Display/Control	Multifunctional four button "softkey" touch panel with continuous display of operating parameters and process mode				
Safety Features	Power fail-safe Internal leak detection alarm PassKey access Protected incoming power supply Low voltage control circuit Optional remote display Audio-visual alarm warnings Pump thermal overload				
System Monitoring	Recirculation flowrate indicator in liters/US gallons per minute Recirculation pressure indicator in bar/psi Recirculation status Reservoir level in liters/US gallons				
	N/a		Product water quality (MΩ·cm or µS/cm) Product water temperature (°C) Consumable change reminder		
Outputs	RS 232 Interface – D 9 connector for printer and PC BMS connection – volt free contact – internal Remote display available via RS485				
Power Requirements	208 – 230V/50Hz				
Special Features			Auto sanitization	Auto sanitization RO Permeate rinse	
	Optional kit for record of operating parameters User adjustable operational time framework Optional Remote Display/Control (max 8)				
Typical Flowrate	Up to 18 L/min on standard models or a maximum of 30 L/min ⁴ HFV models @ 3 Bar (45 psi)				
Reservoir Volume	200 Liters (53 US gallons)	350 Liters (92 US gallons)			
Feedwater Specifications					
Source				Original feed should be potable water	
Maximum FI	N/a			5	
Temperature	5-35°C (41-95°F)				
Pressure maximum	10 bar (145 psi)			3 bar (44 psi)	
Pressure minimum	N/a			1 bar (14.5 psi)	

¹ Subject to correct operating and maintenance procedures

² Subject to use of a suitable deionization cylinder

³ Subject to feedwater

⁴ Subject to the distribution loop design.



the CENTRA range

In addition to the CENTRA, ELGA manufactures a wide range of PURELAB systems for ultra-pure, general laboratory and primary grade water.

Every ELGA CENTRA and PURELAB system has been carefully designed to give you uncompromising water quality in a cost-effective, convenient, and easy to use package.

With a network of over 600 service centers worldwide, ELGA provides an unrivalled package of service and support for its range of pure water systems. Whatever support you require, ELGA's team of water treatment experts will respond quickly to ensure your total satisfaction with our products and services.

With our wide range of technologies, products and services, we can provide the right solution tailored to your own specific pure water needs.

Contact us today for further information on the water purification systems featured in this brochure or for details of other models in the range.

ULTRA-PURE SYSTEMS



GENERAL LABORATORY GRADE SYSTEMS



PRIMARY GRADE SYSTEMS



Contact your nearest ELGA LabWater representative at:

**GLOBAL OPERATIONS CENTER
ELGA**

Tel +44 1494 887 500
Fax +44 1494 887 505

**NORTH AMERICA
USFILTER**

Customer Service
800 466 7873
Technical Support
800 875 7873 Ext 5000

AUSTRIA

Tel +43 2236 506003
Fax +43 2236 50600322

BRAZIL

Tel +55 11 4617 4388
Fax +55 11 4617 4388

CHINA

Tel +86 10 8453 8595
Fax +86 10 8453 8571

DENMARK

Tel +45 43451676
Fax +45 43453524

FINLAND

Tel +358 9 4770 9032
Fax +358 9 4770 9010

FRANCE

Tel +33 1 40 83 65 00
Fax +33 1 40 83 64 50

GERMANY

Tel +49 5141 803 0
Fax +49 5141 803 385

IRELAND

Tel +353 1 630 3333
Fax +353 1 630 3344

MEXICO

Tel +52 5366 6300
Fax +52 5366 6368

NETHERLANDS

Tel +31 318 691 500
Fax +31 318 691 501

SPAIN

Tel +34 91 660 4000
Fax +34 91 666 7716

UAE

Tel +971 6 5570703
Fax +971 6 5570704

UK

Tel +44 1494 887 866
Fax +44 1494 887 837

Visit our website at www.elgalabwater.com E-mail us on info@elgalabwater.com

ELGA® is the global laboratory water brand name of Veolia Water. CENTRA® is an ELGA LabWater trademark and technology. Owing to a policy of continual improvement, we reserve the right to amend the specifications given in this brochure. © 2006 ELGA LabWater/VWS Ltd. All rights reserved.