



MEDICA®

Water purification systems
for clinical analyzers

MEDICA®

The cost-effective and reliable choice for clinical analyzers

MEDICA water purification systems from ELGA are purpose-built to provide optimum performance for one or more clinical analyzers. They feature a unique combination of technologies to produce high purity water cost-effectively.

MEDICA systems have been proven to meet the pure water requirements of all analyzer companies, typically CLRW grade water (CLSI).

CONSISTENT HIGH PURITY WATER FOR CONSISTENT RESULTS

ELGA has been supplying pure water systems for clinical analyzers for over 25 years. We understand how important water quality is in ensuring consistent results from your analyzer. MEDICA systems incorporate the latest technologies to deliver unrivalled performance, reliability and bacterial control. In addition we test components within our systems well beyond the parameters of their daily use so you can have confidence in your pure water supply at all times.

PURE WATER IS VITAL FOR TROUBLE FREE ANALYSIS

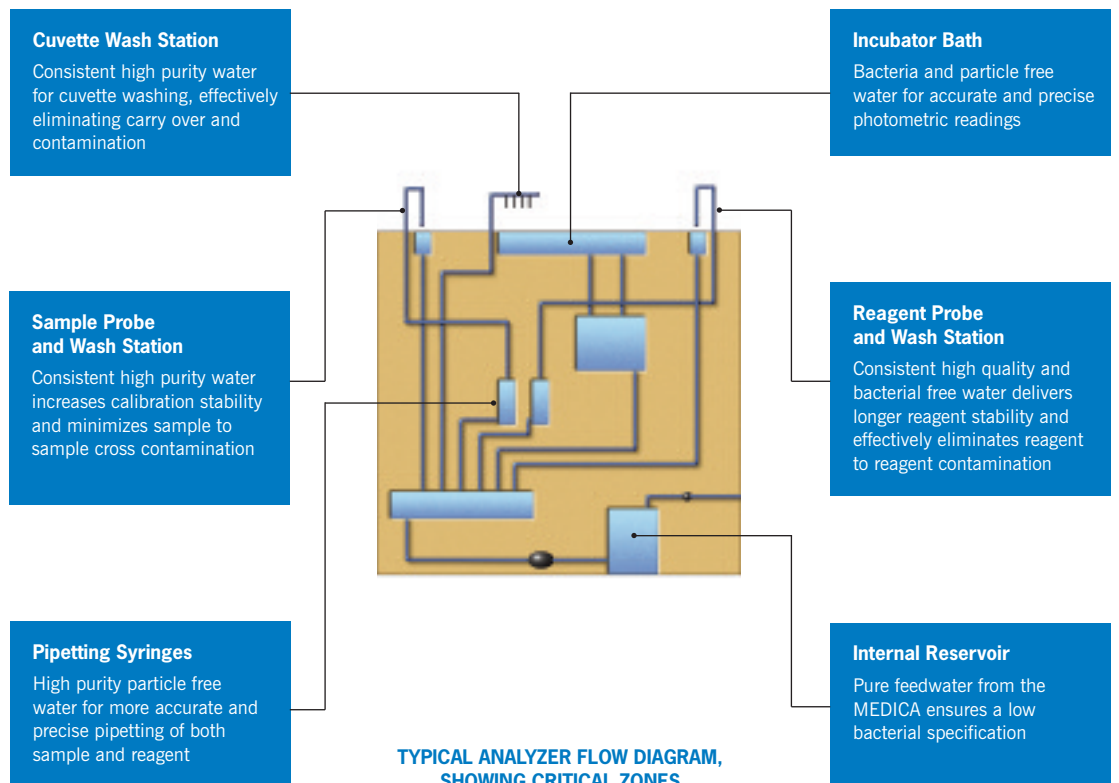

WORLDWIDE SERVICE AND SUPPORT

The demands of clinical analysis mean that the highest quality service and support are essential. As an ELGA customer you will have direct access to our unrivalled worldwide service network:

- Local service technicians, fully trained in MEDICA systems, guarantee the fastest possible response when you need technical support and supplies
- 24 hour hotline in most countries
- A range of maintenance contracts provide an all-risk insurance policy to ensure reliable performance for many years
- Focused, customized training programs for analyzer users and service technicians – developed in conjunction with analyzer companies



A COMMITMENT TO EXCELLENCE

ELGA LabWater has thousands of installations worldwide and our customer base is growing all the time. This success is built on a commitment to technological innovation and excellence in manufacture:

- Ongoing research and development programs to ensure that MEDICA systems continue to evolve to meet the future needs of our customers
- A commitment to the highest quality control processes to deliver reliability and compliance with both international and organization specific standards



The ELGA LabWater Quality Control Center in the UK

MEDICA *range*

THE MEDICA RANGE

MEDICA systems are designed with your analyzer in mind, drawing on ELGA's extensive experience in the clinical analyzer market. Within the range there is a choice of models and flow rates to meet the requirements of low and higher volume clinical analyzers or multiple analyzers located throughout a laboratory on a distribution loop system.



Model	MEDICA-S/R/D 7/15	MEDICA Pro-S/R/RE	MEDICA-R 200
Nominal water usage rates @15°C	7 L/hr, 15 L/hr	30 L/hr, 60 L/hr, 120 L/hr	200 L/hr
Applications	Feed to clinical chemistry and immunodiagnostic analyzers		
Water purity	>10MΩ-cm at 25°C; (<0.1μS/cm) TOC of <30ppb; Bacteria levels of <1 CFU/ml; Dissolved oxygen 5-7 ppm (MEDICA-D)	>10MΩ-cm at 25°C; (<0.1μS/cm) TOC of <30ppb; Bacteria levels of <1 CFU/ml;	>10MΩ-cm at 25°C; (<0.1μS/cm) TOC of <30ppb; Bacteria levels of <10 CFU/ml;
Water purity standards	Conforms to: CLRW grade water (CLSI), ASTM D1193 Type IIIC, ISO 3696 Grade 1, USP 25 Purified Water, BP/EP Purified Water		
Purification technologies	Pretreatment Reverse osmosis Ion exchange Photo-oxidation 0.2μm microfiltration Recirculation (MEDICA-R/D) Deaeration (MEDICA-D)	Pretreatment Reverse osmosis Ion exchange Photo-oxidation 0.05μm ultra-microfiltration Recirculation (MEDICA Pro-R/RE) Degassing (MEDICA Pro-RE) Optional degassing (MEDICA Pro-S/R)	Pretreatment Reverse osmosis External ion exchange Photo-oxidation 0.2μm microfiltration Recirculation

MEDICA-S/R/D 7/15

Designed to directly feed low volume clinical analyzers with up to 1.8 liters per minute of CLRW grade water (CLSI).



- **Easy operation and control** – incorporates easy-to-read displays to enable you to check water quality, water temperature and consumables at a glance
- **Guaranteed water quality** – you can customize the audible and visual alarms on the system to ensure it delivers the specific water quality you require at all times
- **Recirculation of purified water on the MEDICA-R 7/15** – ensures a consistent high quality with a low bacterial specification
- **Emergency by-pass loop** – in an emergency, such as a power loss, the system can continue to supply pure water to the analyzer via an emergency by-pass loop
- **A multipurpose pure water system** – the integral dispense tap (MEDICA-R) gives you the convenience and economy of having pure water available for other general laboratory applications without compromising the analyzer feed
- **Dissolved oxygen** – the MEDICA-D features a membrane contactor to deliver a reduced dissolved oxygen specification required by some analyzers
- **Saves space in the laboratory** – can be mounted on a bench, under a bench or on a wall. When used with the DV25 Docking Vessel you save even more space by eliminating the need for a separate reservoir
- **Good laboratory Practice** – features an RS232 port to enable you to make a permanent printed record of water quality and system parameters
- **Very easy to maintain** – direct access from the front-entry service doors, plus quick-fit connections, allows easy replacement of consumables
- **A broad range of optional accessories** – includes a printer kit, remote control station and a full range of water storage reservoirs

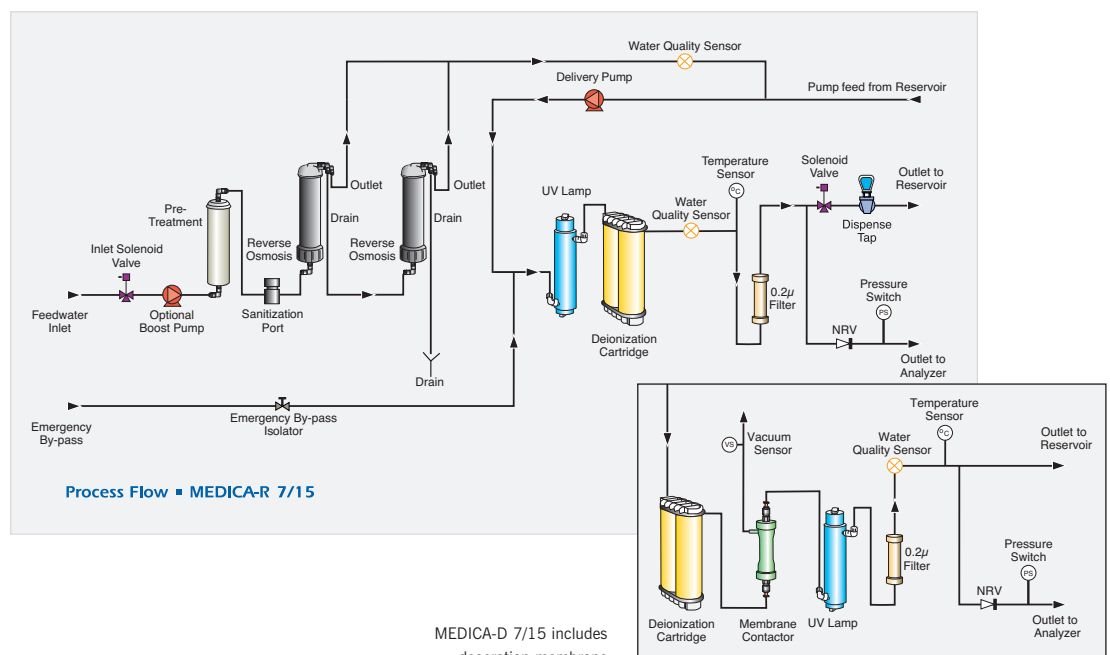

MEDICA Pro

The MEDICA Pro range features four models designed to offer you a choice of configurations for delivering up to 4 liters per minute of CLRW grade water (CLSI) to individual or multiple clinical analyzers.

MEDICA Pro-S – ideal for single analyzers which require a non pressurized feed.

MEDICA Pro-R – designed for pressurized feed to single or multiple analyzers requiring consistent high purity water.

MEDICA Pro-RE – designed to feed single or multiple analyzers which are heavily utilized.

MEDICA Pro-LPS – designed to be fed by prepurified water from a loop or central in-house supply.



The **MEDICA Pro-S, Pro-R** and **Pro-RE** feature:

- **Protek pretreatment cartridge**
 - High capacity adsorbant/pre-filter offers increased protection by minimizing chlorine and chloramines
 - Saves space compared to externally mounted standard carbon filters
 - Quick fit connections reduce installation and maintenance time
- **High flux reverse osmosis** with a make-up rate of 30, 60 or 120 liters per hour
- **Easy upgradeability within the box** – migrate from 30 to 60 or 120 liters per hour to supply higher volume or multiple analyzers without having to replace the whole system

All **MEDICA Pro** systems feature:

- **Medpure DI cartridge** – optimized mix of high performance ion exchange media
- **Traceability for validation purposes** – use of MEDICA Pro's in-built technology assures correct usage and traceability of the replacement cartridges

The MEDICA Pro range at a glance

Model	MEDICA Pro-S	MEDICA Pro-R	MEDICA Pro-RE	MEDICA Pro-LPS
Pretreatment	✓	✓	✓	
Extra capacity pretreatment	Optional	Optional	Optional	
Air gap	✓	✓	✓	✓
Degassing	Optional	Optional	✓	Optional
Reverse osmosis	✓	✓	✓	
Integral 50 liter reservoir	✓	✓	✓	✓
Deionization	✓	✓	✓	✓
2nd Deionization cartridge	Optional	Optional	Optional	Optional
UV Photo-oxidation	✓	✓	✓	✓
Ultra-microfiltration	✓	✓	✓	✓
Recirculation		✓	✓	✓

MEDICA[®] Pro

Unique space saving integral reservoir design

By integrating the reservoir into one system box, the MEDICA Pro delivers a smaller footprint than traditional systems and eliminates the need for a separate tank, pump and pretreatment filter. Installation time is reduced as the unique molded integral reservoir and its level controls are pre-commissioned in the factory. The MEDICA Pro requires no separate set up on site, simply plug in and start.



Microprocessor-controlled system management

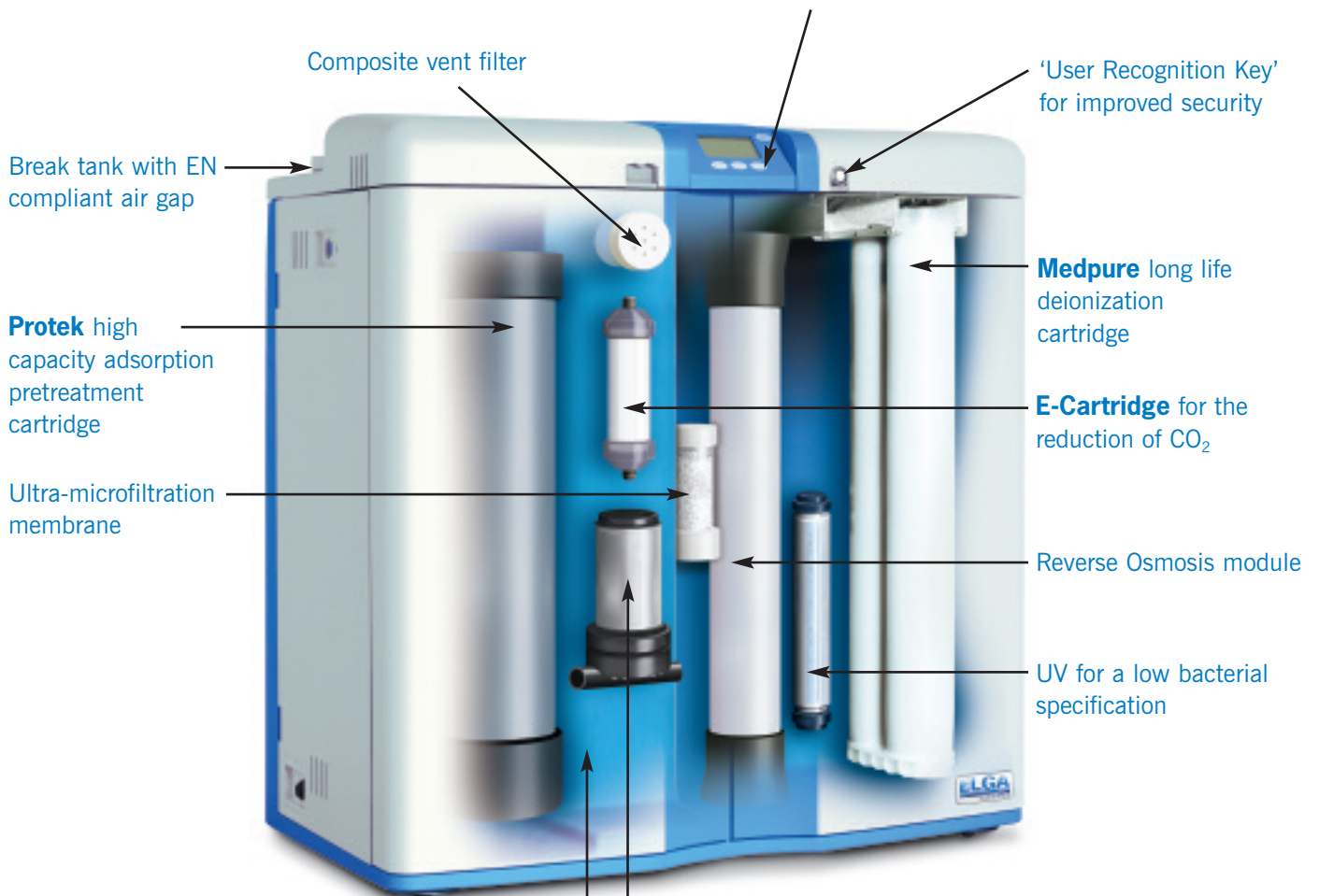

Castors for easy movement of the system

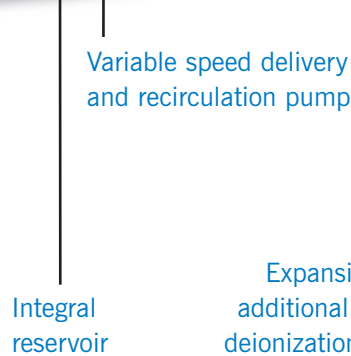

Expansion slot for additional Medpure deionization cartridge

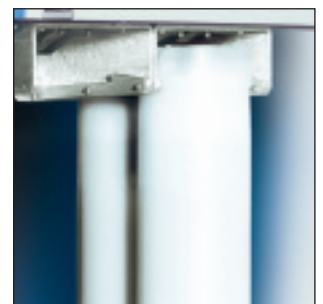

the MEDICA range

The MEDICA Pro range features:

- **Medpure long life deionization cartridges** – enhanced resin mix reduces exchange frequency and running costs. An optional second deionization cartridge can be added to:
 - further reduce exchange frequency
 - deliver a higher flow rate feed to the analyzer
 - increase the emergency by-pass life
- **E-Cartridge for the reduction of CO₂** – available as standard on the MEDICA Pro RE or as an option on other models. CO₂ degassing extends the life of the **Medpure** deionization cartridge in troublesome feedwaters – reducing running costs
- **Low noise variable speed delivery/recirculation pump to maintain water quality** – included as standard on MEDICA Pro R, RE and LPS models. Recirculation automatically slows down in periods of no demand, reducing energy consumption, then speeds up as the analyzer requests water – maintaining the correct flow and pressure to the analyzer
- **Low bacterial specification** – UV and microfiltration technologies together with recirculation and a simple sanitization regime keep bacterial contamination below 1 CFU/ml
- **Semi automatic RO sanitization** – improves bacterial control, reduces user intervention and requires no removal of filters or consumables during the process
- **Emergency by-pass loop** – minimizes down time by providing an uninterrupted supply of pure water to the analyzer in an emergency
- **Improved security with ‘User Recognition Key’ access to settings** – prevents accidental changes to validated set up and controls access to sanitization routines
- **Meets the latest validation requirements** – the MEDICA Pro can be supplied with complete validation documentation
- **Leak detection with automatic shut-down** – minimizes the risk of flooding in the event of a leak within the unit
- **Selectable audio-visual alarms** – for total peace of mind
- **Optional dispense tap** – allows pure water dispensing for general laboratory usage

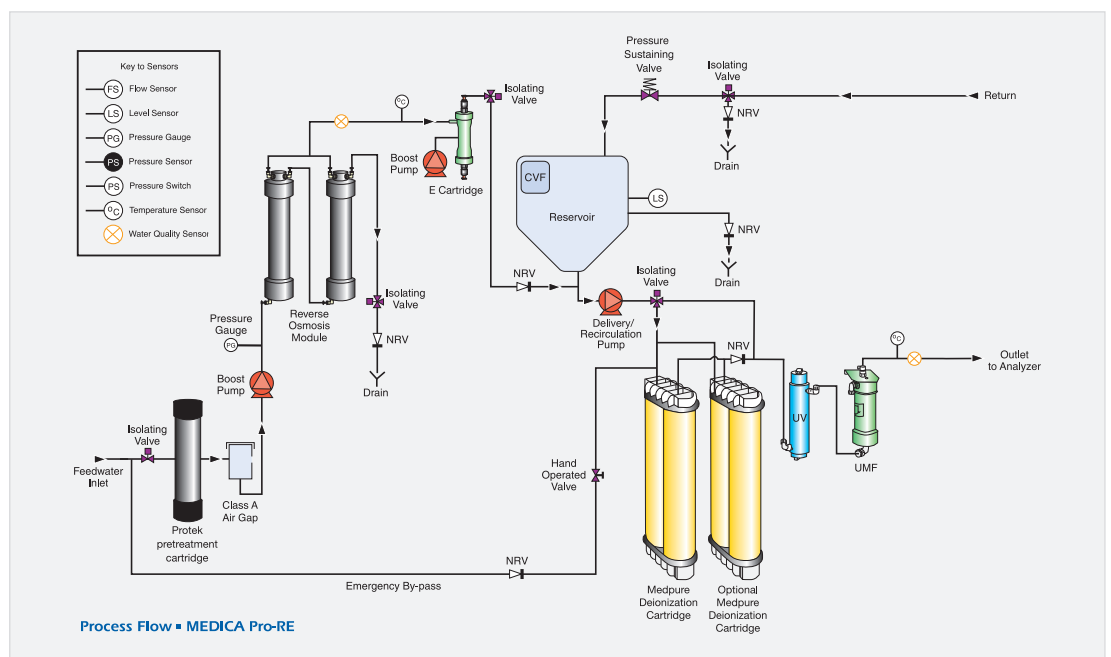

MEDICA-R 200

Designed to supply up to 16 liters per minute of CLRW grade water (CLSI) to higher demand or multiple clinical analyzers on a loop.

The MEDICA-R 200 is the first system to incorporate multiple technologies with a make-up rate of 200 liters per hour in a single award winning unit. Instead of an array of untidy and space consuming components, you can now have just one compact system box plus a deionization cylinder.

- **Quick and easy to install** – Plug and play connections make the MEDICA-R 200 very quick and easy to install, and because it has a small footprint, and an aesthetic design, it can be positioned inside the laboratory as an alternative to a separate plant room
- **Flexible in configuration** – the MEDICA-R 200 can be customized to your particular requirements and is easy to upgrade for a larger loop or to service additional analyzers
- **Guaranteed water quality at high flow rates** – the MEDICA-R 200 cost-effectively guarantees CLRW grade water to the analyzer inlets at a flow rate of up to 16 liters per minute with a maximum volume per day of 4800 liters. This guarantee ensures that you achieve consistent results from your suite of analyzers. As the pure water source for a loop system it is more than capable of feeding several laboratories spread throughout a building
- **Easy operation and control** – monitoring of the system and loop is via a conveniently angled four-button “softkey” control panel at the front of the unit. The panel features a large high contrast LCD display enabling performance parameters, operational mode and process flow to be checked at a glance
- **Remote monitoring of the loop** – up to 8 additional remote display/control panels can be connected to the system. In addition the MEDICA-R 200 can be easily connected to new or existing building management systems

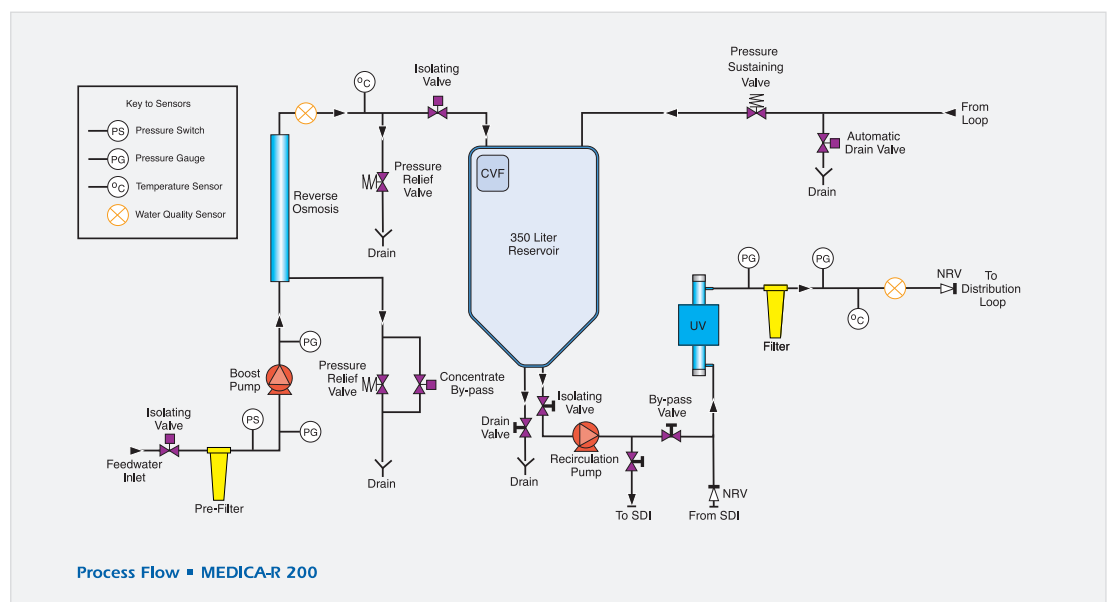

the MEDICA range

COMPLETE SECURITY

The MEDICA-R 200 incorporates a wide range of safety features and alarms to ensure pure water quality is not compromised.

- **Unique PassKey access** to the control panel protects important functions and prevents accidental changes to settings & calibrations. Different tiers of security are provided for flexibility of operation
- **An internal leak detection system and shut-off** for peace of mind
- **An integrated by-pass** ensures a continual supply of pure water in the unlikely event of a system failure
- **Audio visual-alarms** are initiated if water quality or reservoir levels get too low
- **A full validation workbook** is available if your MEDICA-R 200 needs to be validated to ensure compliance with regulatory standards



EASY SANITIZATION AND MAINTENANCE

- A manually initiated automatic disinfection routine simplifies sanitization and maintains control over bacterial levels
- All wetted parts are sanitized and the incorporation of a sprayball at the entry to the storage reservoir ensures full coverage of all surfaces
- Maintenance on the MEDICA-R 200 is very simple and straightforward. Direct access from the front-entry service door, plus quick-fit connections, facilitates easy replacement of consumables

GOOD LABORATORY PRACTICE

MEDICA-R 200 features an RS232 and RS458 port to enable you to make a permanent printed record of performance and system parameters to achieve compliance with Good Laboratory Practice (GLP) guidelines.



TECHNICAL SPECIFICATIONS

Model	MEDICA S/R/D 7/15	MEDICA Pro-S/R/RE	MEDICA R 200
Performance Specifications			
Inorganics at 25°C (77°F)	> 10 MΩ-cm (<0.1μS/cm)	> 10 MΩ-cm (<0.1μS/cm)	> 10 MΩ-cm (<0.1μS/cm)
TOC	<30 ppb	<30 ppb	<30 ppb
Silica	<0.05	<0.05	<0.05
Bacteria¹	<1 CFU/ml	<1 CFU/ml	<10 CFU/ml
Particles	0.2μm filter	0.05μm filter	0.2μm filter
pH	Effectively neutral	Effectively neutral	Effectively neutral
Dissolved Oxygen (MEDICA-D)	5-7 ppm	n/a	n/a
Product Specifications			
Dimensions	Height: 460mm (18.1ins) Width: 550mm (21.7ins) Depth: 270mm (10.6ins)	Height: 820mm (32.3ins) Width: 790mm (31.1ins) Depth: 480mm (18.9ins)	Height: 1820mm (71.7ins) Width: 730mm (28.75ins) Depth: 890mm (35.0ins)
Weight (operational)	MEDICA-S/R 7: 18.5kg (40.8lb) MEDICA-S/R 15: 19.0kg (41.9lb) MEDICA-D 7: 19.0kg (41.9lb) MEDICA-D 15: 19.5kg (43.0lb)	MEDICA Pro-S 118kg (260.0lb) MEDICA Pro-R/RE 120kg (265.0lb)	MEDICA-R 200 540kg (1190.0lb)
Operational Mode Displays	Power on Process on Standby Delivery	Power on Process on Standby Auto-rinse Sanitization	Power on Process on Standby Auto-rinse Sanitization
Safety Features	Emergency by-pass Power fail-safe Automatic level controls Audio-visual alarm warnings Auto-restart	Emergency by-pass Power fail-safe Automatic level controls Audio-visual alarm warnings Automatic sanitization Auto-restart Low feed pressure shut-off Internal leak detection PassKey to prevent unauthorized change of system settings Reset to factory default settings option	Emergency by-pass Power fail-safe with status memory retention Internal Leak detection and shut down PassKey to prevent unauthorized change of system settings Remote display/control inhibit Low voltage electronics Feedwater low level Audio-visual alarm warnings Reset to factory default settings option
System Monitoring	RO permeate quality (μS/cm) Product water quality (MΩ-cm or μS/cm) Product water temperature °C (°F) Reservoir level % full Consumable life indicators	RO permeate quality (μS/cm) RO rejection % Product water quality (MΩ-cm or μS/cm) Product water temperature °C Consumable remaining life indicators Reservoir level liters (US gallons)	Recirculation flowrate indicator in liters per min/USG per min Recirculation status Product water quality (MΩ-cm or μS/cm) Product water temperature °C (°F) Reservoir level liters (US gallons)
Outputs	RS 232 Interface BMS connection Remote display	Optional BMS connection Consumable change reminder	Consumable change reminder RS 232 Interface BMS connection Remote display
Special Features	Optional Remote Control Station Optional kit for record of operating parameters	RO permeate rinse Power saving backlight Commissioning sequence	PC link via a D 9 connector RO permeate rinse RO concentrate purge Optional kit for record of operating parameters Optional remote display/control station (max 8)
Dispense Flows	MEDICA-S/R 1.8 L/min (0.48 USG per min) to analyzer MEDICA-D 1.0 L/min (0.26 USG per min) to analyzer	Up to 4 L/min (1.1 USG per min)	Up to 16 L/min (4.2 USG per min)
Make-up Flow Rate	7/15 liters (1.8/4 USG) per hour	30/60/120 liters (7.9/15.9/31.7 USG) per hour ²	200 liters (53 USG) per hour
Feedwater Specifications			
Source	Potable water	Potable water	Potable water
Maximum FI	10	10	5
Maximum Conductivity	1400 μS/cm	1400 μS/cm	1000 μS/cm
Total Chlorine	<0.5ppm	<0.5ppm	<0.2ppm
Temperature	1-35°C (34-95°F)	1-35°C (34-95°F)	5-35°C (41-95°F)
Pressure Maximum	6 bar (90 psi) ³ 2 bar (30 psi) ⁴	3 bar (45 psi)	4 bar (60 psi)
Pressure Minimum	4 bar (60 psi) ³ flooded suction ⁴	2 bar (30 psi)	2 bar (30 psi)

¹ Subject to correct operating and maintenance procedures

² @ 15°C (59°F)

³ Without boost pump

⁴ With boost pump

the MEDICA range

FREE CLINICAL LABWATER GUIDE

Our Clinical LabWater Guide is a must for anybody involved in the management and operation of clinical analyzers. It is packed with detailed information about pure water and why it is vital to the efficient operation of the analyzer and the accuracy of test results. The guide also looks at important issues such as validation, current trends in clinical monitoring and advised guidelines from CLSI®.



For a free copy please contact your local distributor or go online at www.elgalabwater.com.



THE SINGLE SOURCE SOLUTION

In addition to the MEDICA®, ELGA manufactures a wide range of PURELAB® systems for ultra-pure, general laboratory and primary grade water. Every ELGA MEDICA and PURELAB system has been carefully designed to give you uncompromising water quality in a cost-effective, convenient, and easy to use package.

With a network of over 600 service centers worldwide, ELGA provides an unrivalled package of service and support for its range of pure water systems. Whatever support you require, ELGA's team of water treatment experts will respond quickly to ensure your total satisfaction with our products and services.

Contact your nearest ELGA LabWater representative at:

ELGA GLOBAL OPERATIONS CENTER

Tel +44 1494 887 500

Fax +44 1494 887 505

ELGA COUNTRY OPERATIONS

ARGENTINA

Tel +54 11 4302 7181

Fax +54 11 4302 7180

AUSTRIA

Tel +43 2236 506003

Fax +43 2236 50600322

BRAZIL

Tel +55 11 4617 4388

Fax +55 11 4617 4388

CHINA

Tel +86 10 8453 8595

Fax +86 10 8453 8571

DENMARK

Tel +45 43451676

Fax +45 43453524

FINLAND

Tel +358 9 4770 9032

Fax +358 9 4770 9010

FRANCE

Tel +33 1 40 83 65 00

Fax +33 1 40 83 64 50

GERMANY

Tel +49 5141 803 0

Fax +49 5141 803 385

IRELAND

Tel +353 1 630 3333

Fax +353 1 630 3344

MEXICO

Tel +52 55 5366 6300

Fax +52 55 5366 6363

NETHERLANDS

Tel +31 318 691 500

Fax +31 318 691 501

SPAIN

Tel +34 91 660 4000

Fax +34 91 666 7716

TAIWAN

Tel +886 2 2278 1006

Fax +886 2 2278 1002

UAE

Tel +971 6 5570703

Fax +971 6 5570704

UK

Tel +44 1628 897000

Fax +44 1628 897001

USA

Tel 800 466 7873 (Siemens)

ELGA AUTHORISED DISTRIBUTORS

ELGA Distributors, fully trained in all ELGA systems, are located in over 60 other countries – visit the country list on our website or contact our Global Operations Center at the number above.

Visit our website at www.elgalabwater.com E-mail us on info@elgalabwater.com

ELGA® is the global laboratory water brand name of Veolia Water. MEDICA® and PURELAB® are ELGA LabWater trademarks and technologies. Owing to a policy of continual improvement, we reserve the right to amend the specifications given in this brochure. © 2008 ELGA LabWater/VWS (UK) Ltd. All rights reserved.